

FMR15102

2-Channel 151MHz Receiver

Features

- Two channel receiver with relay outputs
- Supply voltage can be AC or DC
- Low current consumption
- Built-in noise or signal strength indicator
- User can select 8 different frequencies
- Momentary, Latching and Security latching modes are all user selectable
- Easy code setup with dip switch settings
- Optional QM100 bracket available for easy mounting to cases or walls.

C1015 or C1020 case is also available

Applications.

- Pump Control
- Long distance panic button
- On/Off applications in agricultural devices
- Security alarm
- Basic Telemetry eg. Water level indication

Description

This receiver gives you two relay outputs with a contact rating of 5 amps at 240VAC. The relay mode can be set to momentary, latching or security latching.

The user can select 8 different narrow band frequencies and program unlimited number of transmitters to the receiver. With a narrow band FM 151MHz signal from the transmitter a line of sight operating range of 5000 metres is possible. The receiver uses a crystal oscillator circuit that ensures high frequency stability allowing optimal performance in the receiving range.

Output Modes

Relay output on the receiver can function in either momentary or latching mode. By default the mode is set to momentary. Modes selectable from the 2-way dipswitch. Dipswitch 1 corresponds to relay channel 1 and dipswitch 2 corresponds to relay channel 2.

Factory Default = Momentary

Momentary - Output is active for as long as the transmitter button is pressed.
This is a standard mode on most automatic gates or garage door openers.

Latching - Output remains active until next press of the transmitter button.
Similar to switching "on" and "off" a light.

Security Latching - Output remains active until power to the receiver is removed. Similar to security alarms and fire alarms. To activate the security latching mode, a link needs to be soldered into the hole marked as latching.

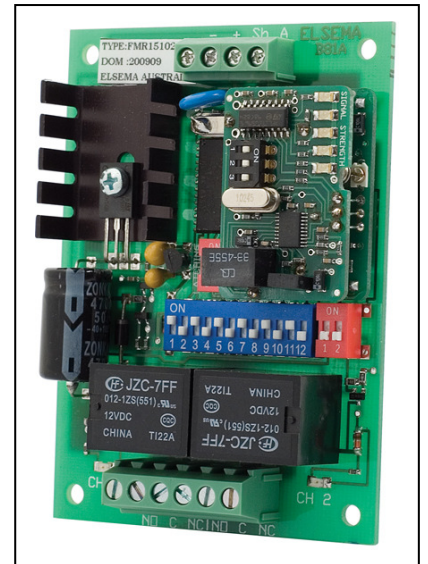

Coding

The 12 way dip switch on the receiver sets the 12 bit unique code for the system. This has to be matched to that on the transmitter.

Apart from the 12 way dip switch there will be an additional dip switch depending upon the receiver type:

- Two channel receivers will have a 2 way dip switch.

This DIP switch on the right side of the 12 way dip switch denotes the channel. See table below.

Generally to use a 2 channel Tx to 2 channel Rx match all the 14 dip switch (12way + 2way just on the right side of the 12 way).

To use a 2 channel Tx to control 2 x single channel receivers, first match the 14 dip switch positions and on the receiver, 15th dip switch OFF is Ch1 and 15th dip switch ON is Ch2.

To use a 2 channel receiver with 2 x single channel transmitters, first match 14 dip switch and then the Tx with Sw15 OFF will activate the Ch1 on the receiver and the Tx with Sw15 ON will activate the Ch2 on the receiver.

FMR15102

2-Way DIP Switch & 2 Relay Output

SW13	SW14	Relay 1	Relay 2
OFF	OFF	Ch1	Ch2
OFF	ON	Ch3	Ch4
ON	OFF	Ch5	Ch6
ON	ON	Ch7	Ch8

Signal Strength Indicator

The 151MHz receivers have five blue LED's on the board. The table below indicates the level of the valid transmitted signal.

5 LED's on	-70dBm	Very Strong signal	Very Reliable operating conditions
4 LED's on	-75dBm	Very Strong signal	Very Reliable operating conditions
3 LED's on	-80dBm	Very Strong signal	Very Reliable operating conditions
2 LED's on	-90dBm	Strong signal	Very Reliable operating conditions
1 LED on	-100dBm	Good signal	Reliable operating conditions

Noise Strength Indicator

If more than 1 led is "ON" without a valid transmission, this indicates that there is noise on the frequency selected. Change the **3-way dipswitch** on the **receiver module** to select a different frequency. Following is a table with the Dipswitch settings and the corresponding frequencies.

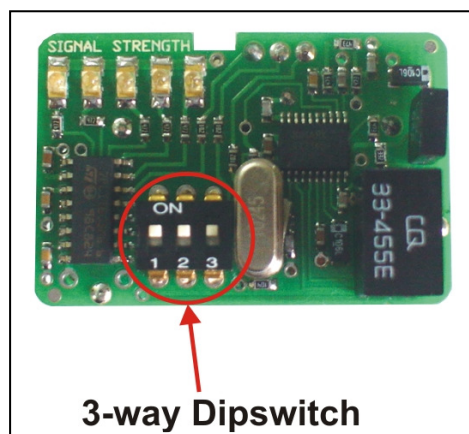









Frequency	1	2	3
151.600 MHz	On	On	On
152.375 MHz	Off	On	On
151.775 MHz	On	Off	On
151.400 MHz	Off	Off	On
151.175MHz	On	On	Off
151.025 MHz	Off	On	Off
150.900 MHz	On	Off	Off
150.825 MHz	Off	Off	Off

Technical Data

Supply Voltage	11.0 - 28.0 VDC 10.0 - 28.0 VAC Can use Elsema AC power pack (PP12 / PP24) Supply lines should be less than 3m long to comply with radio frequency authorities
Current Consumption	24mA Standby at 12VDC 85mA if both relay "ON" at 12VDC
Receiving Frequency	151.6MHz (8 selectable frequencies. See table above)
Operating Temperature Range	-5 to 50°C
Sensitivity	Better than 0.5uV (For relay to activate)
Type of Demodulation	Narrow-Bandwidth Frequency Modulation (FM)
Connection	Supply, Antenna & Outputs - Screw type terminal block
Antenna	50Ω, 151MHz Antenna, Elsema ANT151M for maximum performance A piece of approximately 1metre wire can be used for short range applications
Dimensions	95 x 70 x 20mm
Mounting Hole Size	3.97mm or 5/32"
Weight	83g
Useable Transmitters	All FMT151 series (with correct setting on the dip switch). See Transmitter datasheet for details.
Useable operating range	Up to 5000 metres, depending on installation and type of antenna used. Recommended Antenna is Elsema ANT151M

Products in the Range

			
<p>FMR15101 1-Channel</p>	<p>FMR15102 2-Channel</p>	<p>FMR15101240 1- Channel 240VAC Supply</p>	<p>FMR15102240 2- Channel 240VAC Supply</p>
			
<p>FMR15104 4-Channel</p>	<p>FMR15104240 4- Channel 240VAC Supply</p>	<p>FMR15108 8-Channel</p>	<p>FMR1510812R 8-Channel, 12V Supply</p>
			
<p>FMR1510824R 8-Channel, 24V Supply</p>			

Block Diagram

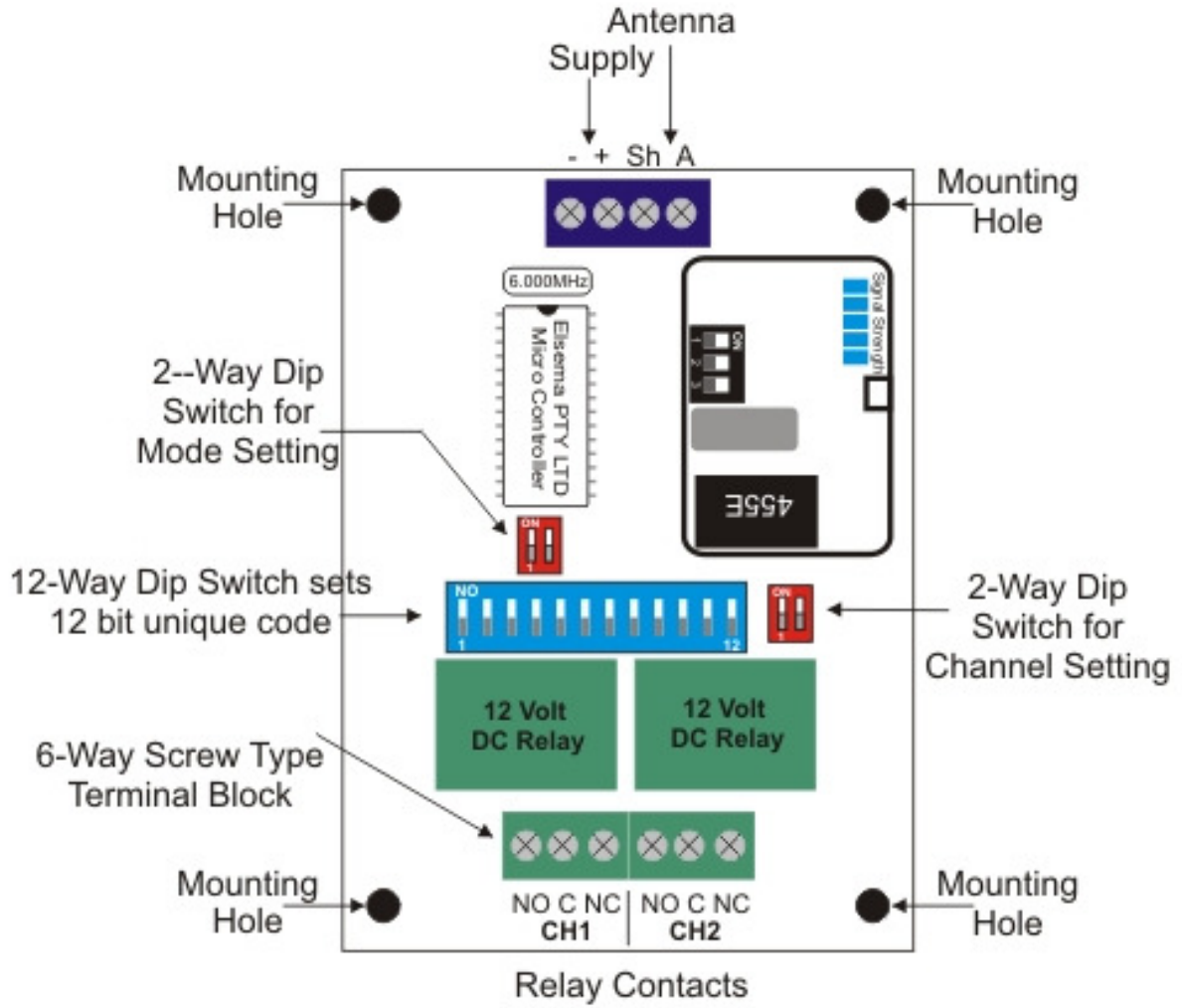

FMR15102 12/24 VAC/DC Application

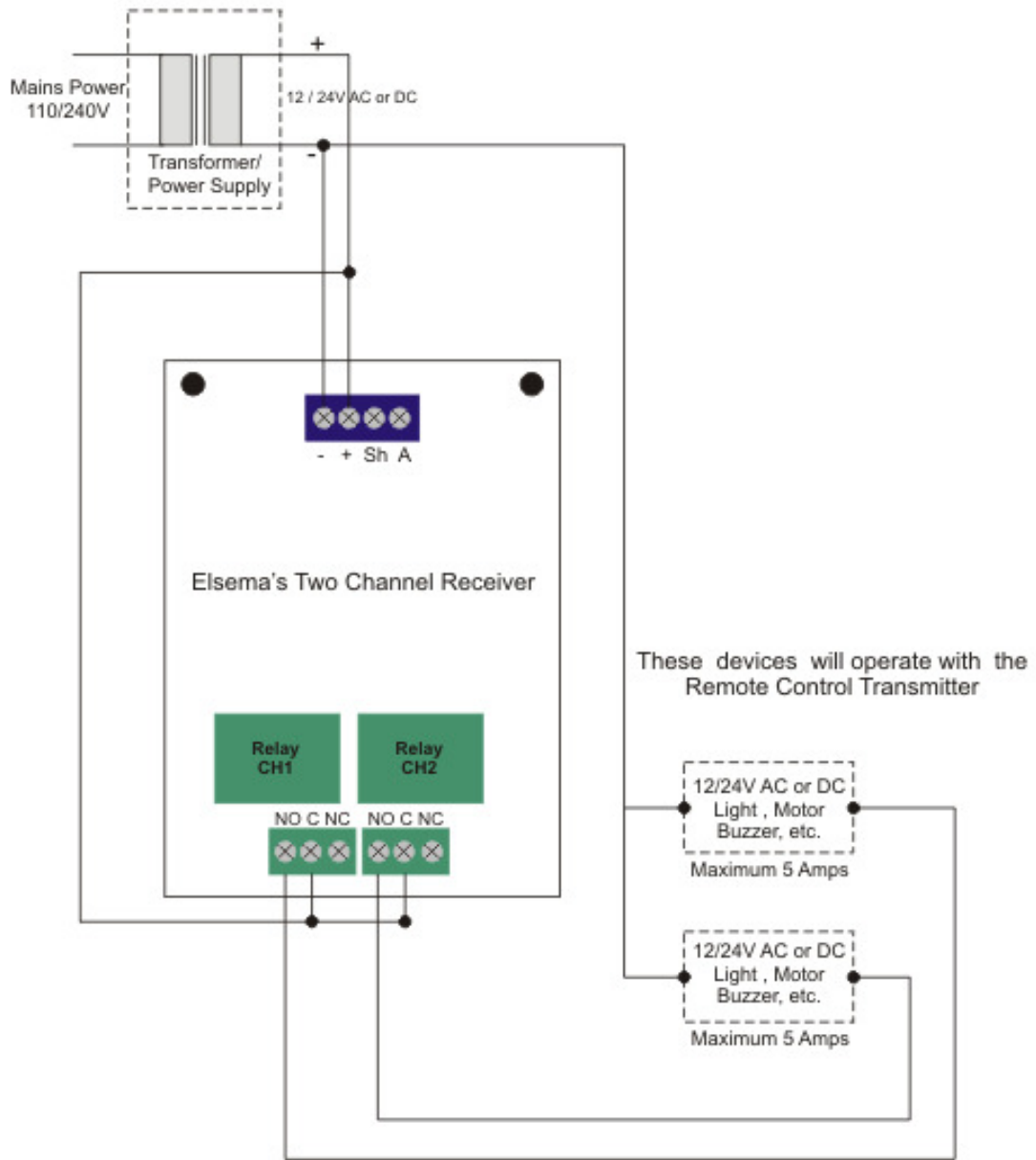

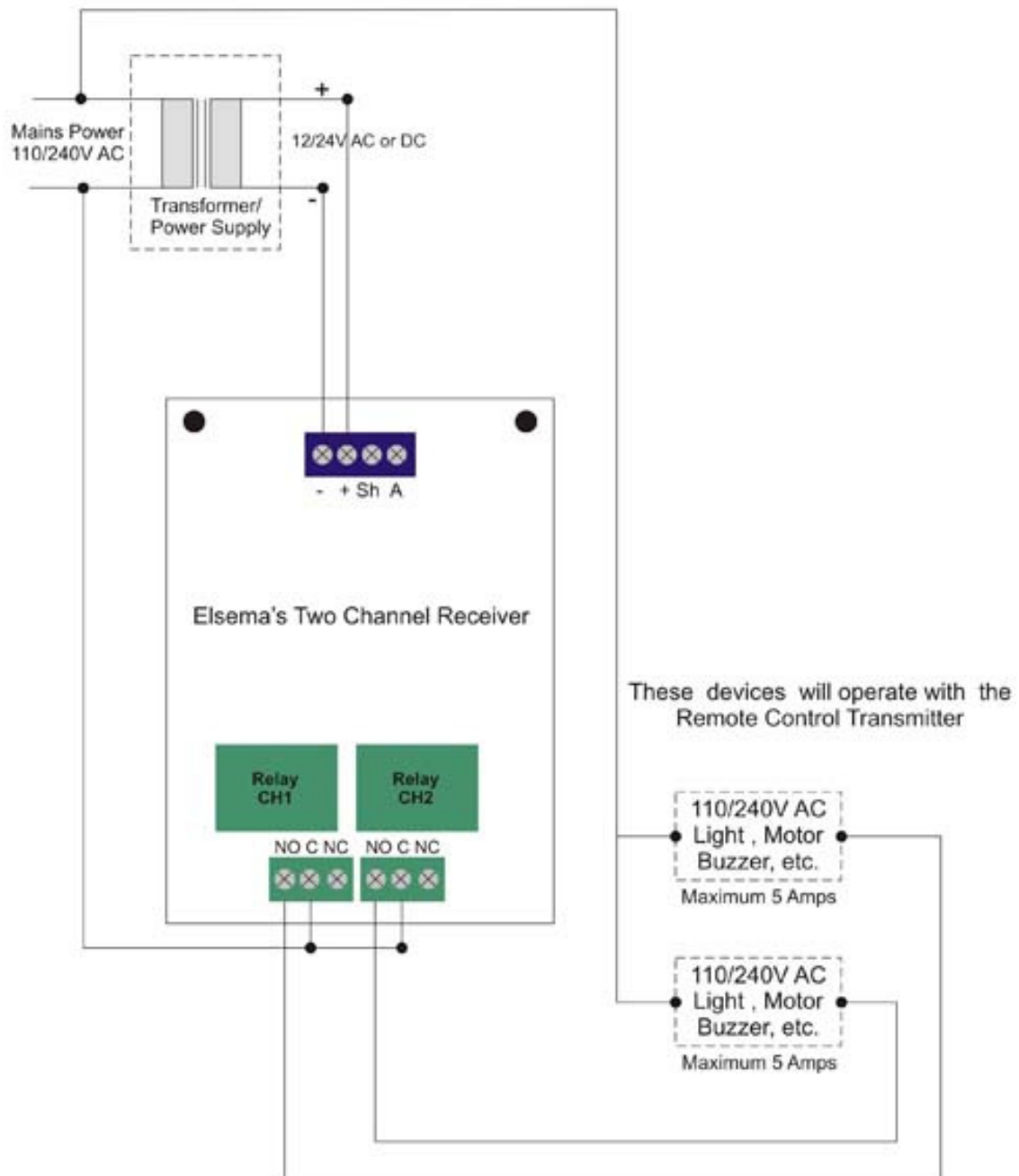
FMR15102 110/240 VAC Application**Manufactured by****Elsema Pty Ltd**

31 Tarlington Place, Smithfield

NSW 2164

Ph: 02 9609 4668

Fax: 02 9725 2663

Website: <http://www.elsema.com>